

# FOX

## Rotary limit switch



Rotary limit switch used to control and measure the movement of industrial machines by measuring the rotation angle and/or counting the number of revolutions of a shaft.  
Fox is used on wind turbines to control the position of the nacelle or the pitch angle of the blades.

### FEATURES

- It consists of a gear motor that transfers movement to the cams and the other movement detection devices through a primary input reduction stage (worm gear and helical toothed gear) and one or more secondary output stages (pairs of straight toothed gears).
- Accurate adjustment of cams by means of screws.
- Positive opening NC contacts for safety functions.
- Mechanical life of switches: up to 10 million operations.
- IP protection degree: Fox is classified IP66, IP67 and IP69K.
- NEMA protection degree: Fox is classified Type 4X\*.
- Extreme temperature resistance: -40°C to +80°C.
- It features transmission and gear driving shafts made of stainless steel AISI 430F or AISI 303. worm gear transmission shaft rotating on ball bearings, self-lubricating technopolymer gears and driving bushes, technopolymer base and cover.
- All materials and components used are wear resistant and guarantee protection of the unit against water and dust.

### OPTIONS

- Revolution ratios from 1:3 to 1:2870. achieved by combining different secondary output stages.
- Snap action switches with 1NO+1NC change-over contacts or slow action switches with 1NC contact.
- It can be equipped with a cam set (with up to 5 switches) and potentiometers, encoders. Yankee absolute encoders.
- Dedicated cable clamps or connectors.
- Available with anti-moisture plug fitted to the base by means of a lock nut, to improve transpiration for the limit switch whilst maintaining protection against water.
- Available with flanges, pinions and couplings.
- Plates with universal adapter to replace existing systems.

### CERTIFICATIONS

- CE marking, cULus\* marking and EAC certification.
- Fox is available, upon request, with the SIL1 certification (Safety Integrity Level 1), according to Standard IEC61508.
- Complies with accident prevention regulation BGV C 1 (only for Germany)
- HALT TEST (Highly Accelerated Life Test) passed. simulating conditions largely exceeding standard operating conditions.

\* Not available on all versions.

## POSSIBLE ASSEMBLIES

With set of cams. Yankee and flange

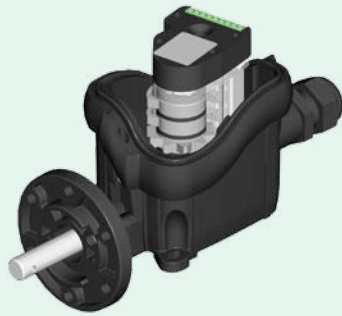

With anti-moisture plug



## CERTIFICATIONS









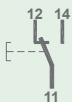
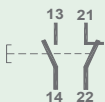
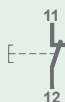

Conformity to Community Directives	2014/35/UE Low Voltage Directive
	2006/42/CE Machinery Directive
	EN 60204-1 Safety of machinery - Electrical equipment of machines
Conformity to CE Standards	EN 60204-32 Safety of machinery - Electrical equipment of machines - Requirements for hoisting machines
	EN 60947-1 Low-voltage switchgear and controlgear
	EN 60947-5-1 Low-voltage switchgear and controlgear - Control circuit devices and switching elements - Electromechanical control circuit devices
	EN 60529 Degrees of protection provided by enclosures
Conformity to cULus Standards	CSA-C22.2 No 14-13 Industrial Control Equipment
	UL 508 Industrial Control Equipment
SIL1	IEC 61508:2010 Part 2-4-6-7 Functional safety of electrical / electronic / programmable electronic safety-related systems
BGV C 1	Regulations for the prevention of accidents BGV C 1 (only for Germany)
HALT TEST	Highly Accelerated Life Test, simulation of conditions largely exceeding the standard operating conditions (data available on request)
Markings and homologations	CE cULus* EAC

## GENERAL TECHNICAL SPECIFICATIONS

Ambient temperature	Storage -40°C/+80°C
	Operational -40°C/+80°C
IP protection degree	IP 66/IP 67/IP 69K
NEMA protection degree	Type 4X*
Insulation category	Class II
Maximum rotation speed	Revolution ratios $\geq 1:16$ : max. 800 rpm
	Revolution ratios $< 1:16$ : max. 200 rpm
Cable entry	Cable clamp M20
	Cable clamp M20+M16
	Cable clamp M20+M20

\* Not available on all versions.

## TECHNICAL SPECIFICATIONS OF THE MICROSWITCHES

Code	PRSL0100XX	PRSL0110XX	PRSL0111XX
Utilisation category	AC 15 DC 13	AC 15	
Rated operational voltage	125 Vac/AC 15 230 Vac/AC 15 60 Vdc/DC 13	250 Vac	
Rated operational current	2 A/125 Vac/AC 15 1 A/ 230 Vac/AC 15 0.5 A/60 Vdc/DC 13	3 A	
Rated thermal current	6 A	10 A	
Rated insulation voltage	250 Vac	300 Vac	
Mechanical life	1.5x10 <sup>6</sup> operations	10x10 <sup>6</sup> operations	
Connections	Screw-type terminal with self-lifting pad	Screw-type terminal	
Wires	0.25mm <sup>2</sup> - 1.5 mm <sup>2</sup>	1x2.5 mm <sup>2</sup> , 2x1.5 mm <sup>2</sup> (UL (c)UL: use 60°C or 75°C copper (CU) conductors and stiff or flexible wire 14-16 AWG)	
Tightening torque	0.5 Nm - 0.6 Nm	0.5 Nm	
Microswitch type	Single break. snap action	Double break. snap action	Double break. slow action
Contacts	1NO+1NC change-over contacts (All NC contacts are of the positive opening operation type) 	1NO+1NC change-over contacts (All NC contacts are of the positive opening operation type) 	1NC (All NC contacts are of the positive opening operation type) 
Scheme			
Markings and homologations	     (general purpose)	  	

## TECHNICAL SPECIFICATIONS OF THE POTENTIOMETERS

Code of potentiometer with support	PA020001	PA020002
Ohmic value	10 kΩ	10 kΩ mechanical stop
Resolution	Infinite	
Independent linearity	±1%	
Life time	10x10 <sup>6</sup> movements	
Operational ambient temperature	-55°C/+105°C	
Continuous rotation (without stop)	360°	
Continuous rotation (with stop)	333° ±5°	
Actual electrical angle	310° ±5°	
Ohmic value tolerance	±20%	

Code of potentiometer with support	PA020003	PA020004	PA020005
Ohmic value	10 kΩ	10 kΩ	5 kΩ
Connections	4 turrets	3 turrets	4 turrets
Independent linearity (over AEA -3°)	≤±1%	≤±0.35%	≤±1%
Life time	5x10 <sup>6</sup> movements		
Operational ambient temperature	-55°C/+125°C		
Mechanical angle	360° continuous		
Actual Electrical Angle (AEA)	340° ±5°		
Ohmic value tolerance	Max ±20% at 20°C	Max ±10% at 20°C	Max ±20% at 20°C

## TECHNICAL SPECIFICATIONS OF THE ENCODERS

Code with support	PA030001	PA030002
Resolution	36 pulses/rev.	150 pulses/rev.
Operational ambient temperature	-40°C/+85°C	
Code	Incremental	
Supply voltage	4.5 Vdc min. to 30 Vdc max. (35 mA max. - no load)	
Output voltage	Low: 500 mV max. at 10 mA High: (Vin - 0.6) at -10 mA (Vin - 1.3) at -25 mA	
Output current	25 mA max. load per output channel	
Output format	Two channel (A, B) quadrature with Index (Z)	
Phase sense	A leads B clockwise (CW) from the mounting end of the encoder	
Accuracy	+/- 0.8 arc-min.	
Outputs	Push pull	
Electrical protection	Reverse polarity and output short circuit protected	

## CERTIFICATIONS OF THE ABSOLUTE ENCODER YANKEE

Conformity to Community Directives	2014/30/UE Electromagnetic Compatibility (EMC) Directive
	2006/42/CE Machinery Directive
	2014/35/UE Low Voltage Directive (LVD)
Conformity to CE Standards	EN 61326-1 Electrical equipment for measurement, control and laboratory use - EMC requirements
	EN 60529 Degrees of protection provided by enclosures
Conformity to cULus Standards	CSA-C22.2 No 14-13 Industrial Control Equipment
	UL 508 Industrial Control Equipment
Markings and homologations	CE 

## GENERAL TECHNICAL SPECIFICATIONS OF THE ABSOLUTE ENCODER YANKEE

Ambient temperature	Storage -40°C/+80°C
	Operational -40°C/+80°C
IP protection degree	IP 20
Free rotation	360°
Maximum rotation speed	800 rpm

## ELECTRICAL SPECIFICATIONS OF THE ABSOLUTE ENCODER YANKEE

Code	PA01AA01	PA01AB01	PA01AC01
Analog output	Current 4 ÷ 20 mA	Voltage 0 ÷ 10 V	PWM 0 ÷ 100 %
Power supply	12 ÷ 48 Vdc/12 ÷ 48 Vac		
Protection against polarity inversion	Yes		
Absorption	50 mA		
Resolution	12 bit		
Linearity	+/- 0.5°		
Max. hysteresis	0.1°		
Zero Point setting	Through button/wire		
Signal increment direction	CW (standard)/CCW (on request)		
Connections	Terminal board		
Terminal wires	0.14 mm <sup>2</sup> - 1.5 mm <sup>2</sup>		
Terminal tightening torque	0.22 Nm - 0.25 Nm		

# OVERALL DIMENSIONS (mm)

## Standard

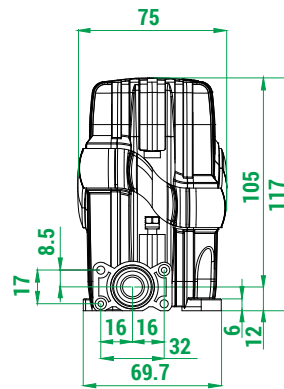
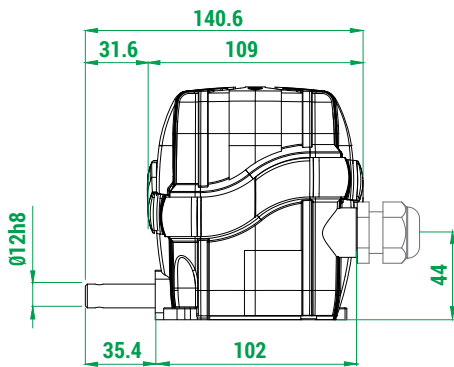
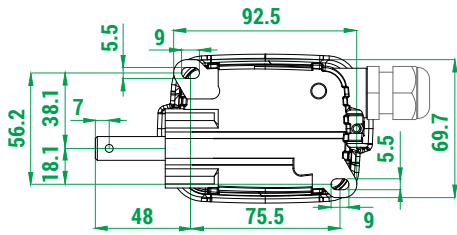

## With flange

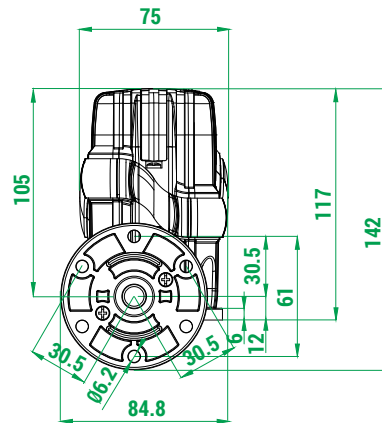
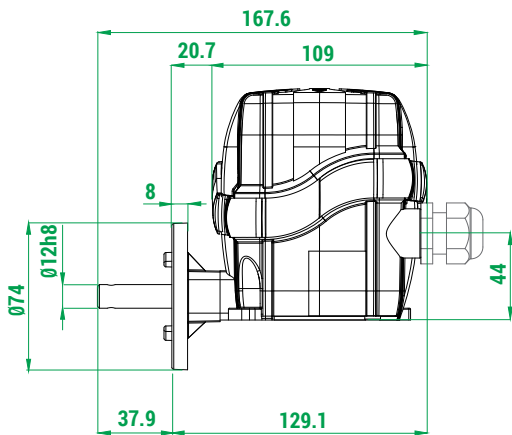
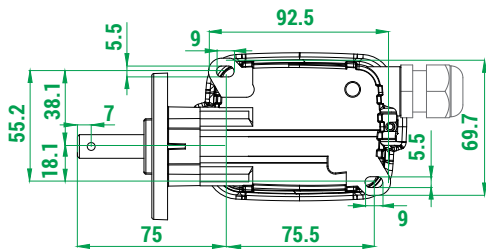



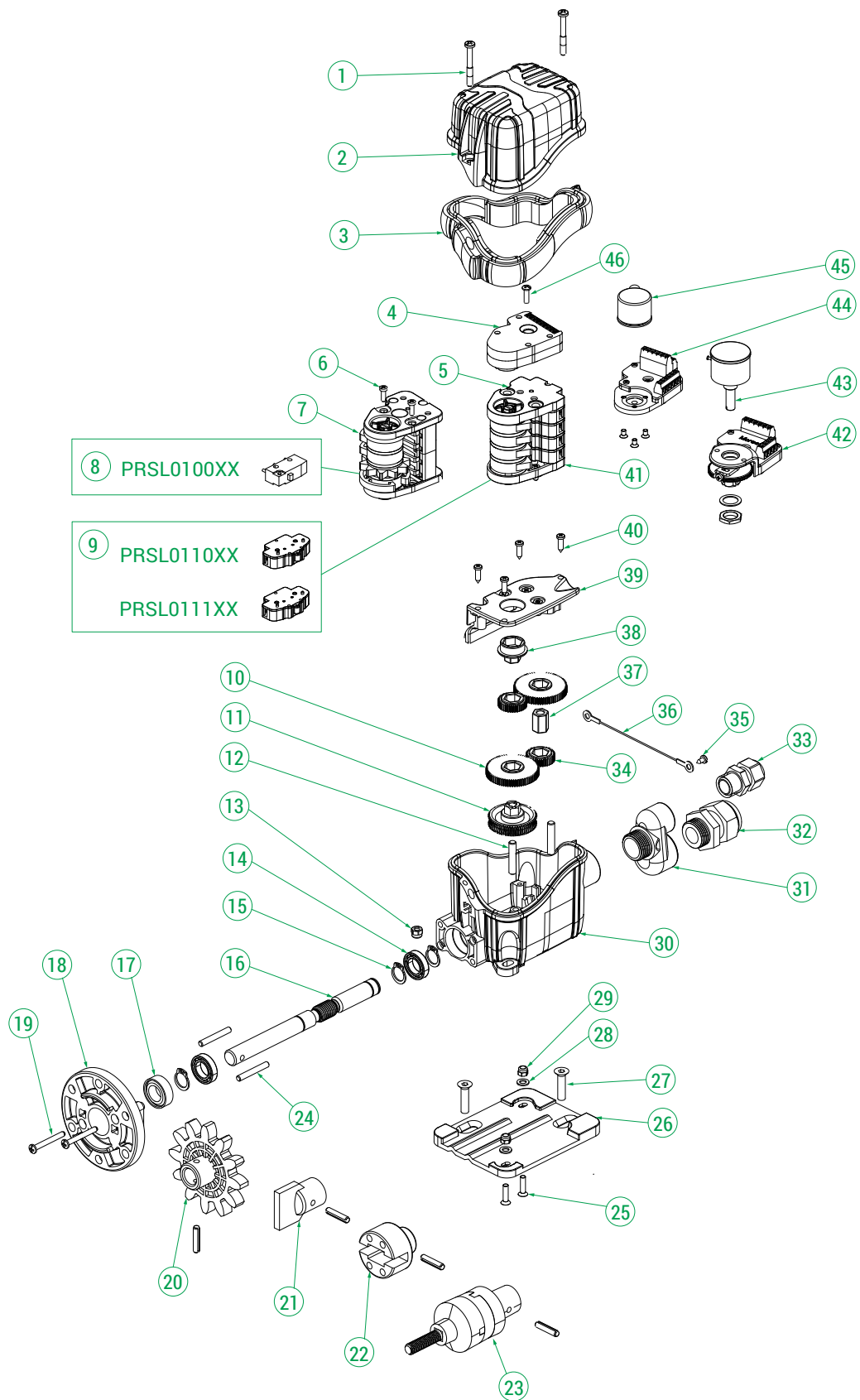

## EXPLODED DRAWING

4



## STANDARD LIMIT SWITCHES

Standard limit switches are equipped with cams PRSL7194PI  for PRSL0110XX and PRSL0111XX switches, cams PRSL7124PI  for PRSL0100XX switches and shafts made of stainless steel AISI 430F. Standard limit switches are not cULus certified.

Rated revolution ratio	Real revolution ratio	No. of cams and switches	Switches		
			PRSL0100XX 1NO+1NC	PRSL0110XX 1NO+1NC	PRSL0111XX 1NC
					
			Code	Code	Code
1:15	1:16	2	PFB9067A0016002	PFB9067L0016010	PFB9067L0016012
		3	-	PFB9067L0016011	PFB9067L0016013
		4	PFB9067A0016003	PFB9067L0016008	PFB9067L0016014
1:20	1:20.21	2	PFB9067A0020001	PFB9067L0020006	PFB9067L0020008
		3	-	PFB9067L0020007	PFB9067L0020009
		4	PFB9067A0020002	PFB9067L0020004	PFB9067L0020010
1:25	1:27.27	2	PFB9067A0027007	PFB9067L0027007	PFB9067L0027017
		3	-	PFB9067L0027016	PFB9067L0027018
		4	PFB9067A0027008	PFB9067L0027014	PFB9067L0027019
1:50	1:62	2	PFB9067A0062006	PFB9067L0062033	PFB9067L0062045
		3	-	PFB9067L0062044	PFB9067L0062046
		4	PFB9067A0062009	PFB9067L0062003	PFB9067L0062025
1:75	1:75.48	2	PFB9067A0075005	PFB9067L0075008	PFB9067L0075010
		3	-	PFB9067L0075009	PFB9067L0075004
		4	PFB9067A0075006	PFB9067L0075006	PFB9067L0075011
1:100	1:103.44	2	PFB9067A0103009	PFB9067L0103037	PFB9067L0103038
		3	-	PFB9067L0103049	PFB9067L0103027
		4	PFB9067A0103008	PFB9067L0103030	PFB9067L0103050
1:150	1:162.52	2	PFB9067A0162006	PFB9067L0162007	PFB9067L0162008
		3	-	PFB9067L0162006	PFB9067L0162009
		4	PFB9067A0162007	PFB9067L0162003	PFB9067L0162002
1:200	1:222.58	2	PFB9067A0222005	PFB9067L0222011	PFB9067L0222014
		3	-	PFB9067L0222013	PFB9067L0222015
		4	PFB9067A0222001	PFB9067L0222010	PFB9067L0222016
1:250	1:254.57	2	PFB9067A0254003	PFB9067L0254019	PFB9067L0254010
		3	-	PFB9067L0254020	PFB9067L0254021
		4	PFB9067A0254004	PFB9067L0254008	PFB9067L0254022

## ASSEMBLY DRAWING

4

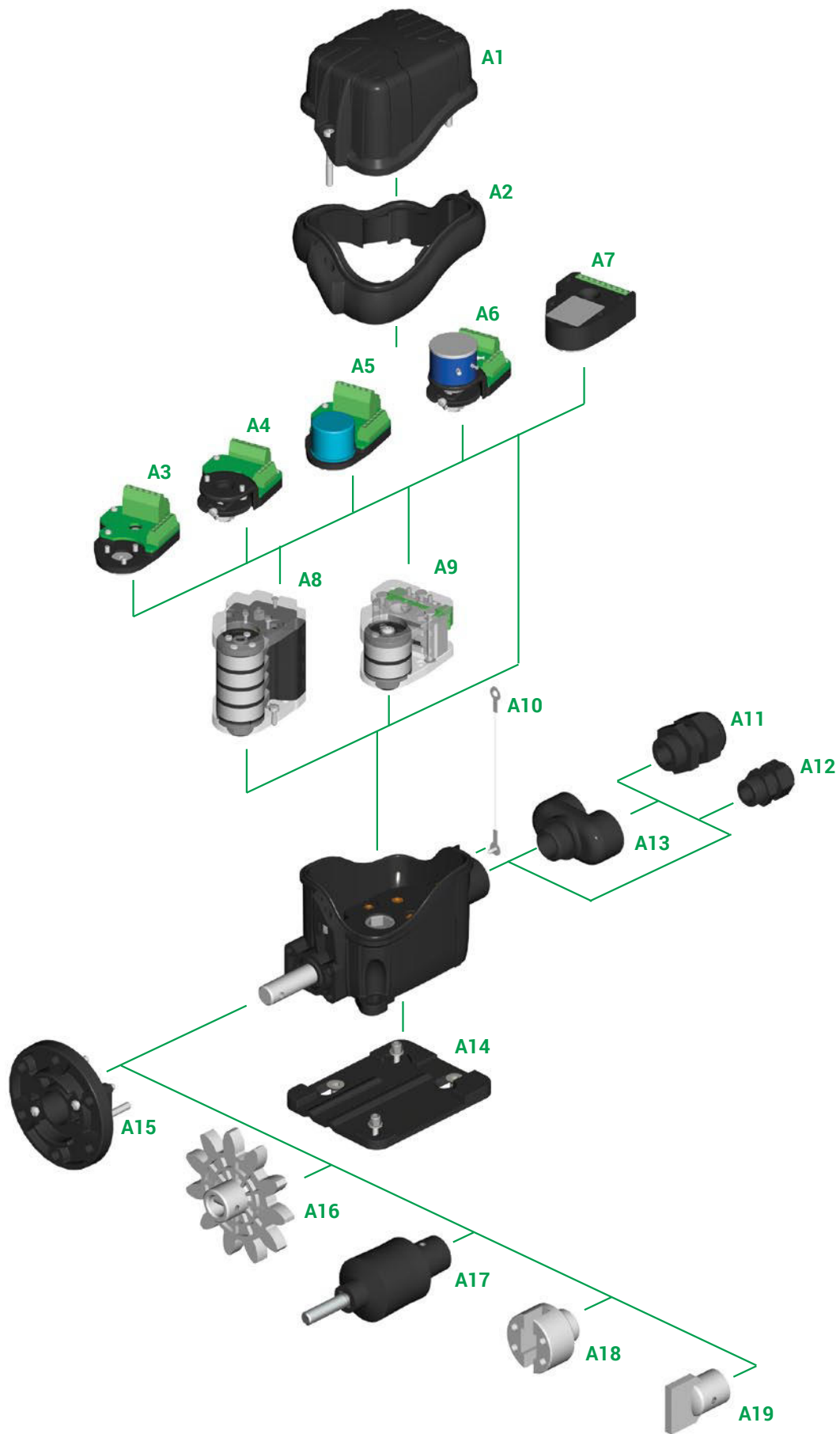









## COMPONENTS

### Standard cam sets





Ref.	Drawing	No. and type of cams	No. and type of switches	Code
A8		2 cams A	2 PRSL0110XX switches	FCL20001
		2 cams A	2 PRSL0111XX switches	FCL20002
		Cams A+C	2 PRSL0110XX switches	FCL20003
		Cams A+C	2 PRSL0111XX switches	FCL20004
		2 cams C	2 PRSL0110XX switches	FCL20005
		2 cams C	2 PRSL0111XX switches	FCL20006
		Cams D+D+B+F	4 PRSL0110XX switches	FCL40001
		Cams D+D+B+F	4 PRSL0111XX switches	FCL40002
		4 cams A	4 PRSL0110XX switches	FCL40003
		4 cams A	4 PRSL0111XX switches	FCL40004
		Cams A+A+C+C	4 PRSL0110XX switches	FCL40005
		Cams A+A+C+C	4 PRSL0111XX switches	FCL40006
		4 cams C	4 PRSL0110XX switches	FCL40007
		4 cams C	4 PRSL0111XX switches	FCL40008
		Cams C+C+C+E	4 PRSL0110XX switches	FCL40009
		Cams C+C+C+E	4 PRSL0111XX switches	FCL40010
A9		2 cams A	2 PRSL0100XX switches	FCN20001
		Cams A+C	2 PRSL0100XX switches	FCN20002
		2 cams C	2 PRSL0100XX switches	FCN20003
		Cams D+D+B+G	4 PRSL0100XX switches	FCN40001
		4 cams A	4 PRSL0100XX switches	FCN40002
		Cams A+A+C+C	4 PRSL0100XX switches	FCN40003
		4 cams C	4 PRSL0100XX switches	FCN40004
		Cams C+C+C+E	4 PRSL0100XX switches	FCN40005
		Cams A+A+E+E	4 PRSL0100XX switches	FCN40006

Other sets with 2/3/4 or 5 cams/switches available on request.  
PRSL0100XX only for 2 or 4 cam sets.





### Cam reference chart

Cam		Code for PRSL0110XX switches	Switching angle with PRSL0110XX	Code for PRSL0111XX switches	Switching angle with PRSL0111XX	Code for PRSL0100XX switches	Switching angle with PRSL0100XX	
A		1 points	PRSL7194PI	21.5° ±0.5°	PRSL7194PI	23.0° ±0.5°	PRSL7124PI	16.0° ±0.5°
B		10 point	PRSL7193PI	21.5° ±0.5°	PRSL7193PI	23.0° ±0.5°	PRSL7123PI	16.0° ±0.5°
C		60° sector	PRSL7195PI	82.0° ±0.5°	PRSL7195PI	86.0° ±0.5°	PRSL7125PI	75.5° ±0.5°
D		72° sector	PRSL7196PI	94.0° ±0.5°	PRSL7196PI	97.5° ±0.5°	PRSL7126PI	88.5° ±0.5°
E		180° sector	PRSL7191PI	204.5° ±0.5°	PRSL7191PI	203.0° ±0.5°	PRSL7121PI	196.0° ±0.5°
F		305° sector	PRSL7192PI	328.5° ±0.5°	PRSL7192PI	327.0° ±0.5°	-	-
G		311° sector	-	-	-	-	PRSL7122PI	327.0° ±0.5°

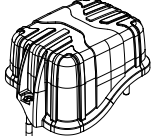
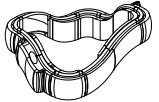

## Potentiometers, encoders and sensors

Ref.	Drawing	Description	Code
A3		Support for encoder	PA030000
A4		Support for potentiometer	PA020000
A5		Encoder 36 pulses./rev. with support	PA030001
		Encoder 150 pulses./rev. with support	PA030002
A6		Potentiometer MCB 10 kΩ with support	PA020001
		Potentiometer MCB 10 kΩ mechanical stop with support	PA020002
		Potentiometer Sfernice 10 kΩ ±10% 4 pins with support	PA020003
		Potentiometer Sfernice 10 kΩ ±10% 3 pins with support	PA020004
		Potentiometer Sfernice 5 kΩ ±10% with support	PA020005
A7		Absolute encoder Yankee - current output	PA01AA01
		Absolute encoder Yankee - voltage output	PA01AB01
		Absolute encoder Yankee - PWM output	PA01AC01

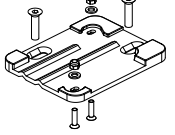
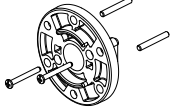
## Accessories

Ref.	Drawing	Description	Code
A1		Cover with screws	PA090017
A2		Tightening rubber	PRGU1500PE
A10		Cover holding wire + screw (bag with 10 pieces)	PRSL0358PI
A11		Cable clamp M20	PRPS0064PE
A12		Cable clamp M16	PRPS0062PE
A13		Cable clamp holder with 2 outputs M20	PRSL9051PI
		Cable clamp holder with 2 outputs M20+M16	PRSL9052PI
A14		Fixing plate	PRSL0430PI
A15		Flange with screws and pins	PRSL0356PI

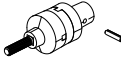
Accessories

Ref.	Drawing	Description	Code
A16		Pinion gear	See pinion gear tables
A17		Coupling with pin	PRSL0981PI
A18		Male coupling with pin	PRSL0919PI
A19		Female coupling with pin	PRSL0920PI

Moulded pinion gears

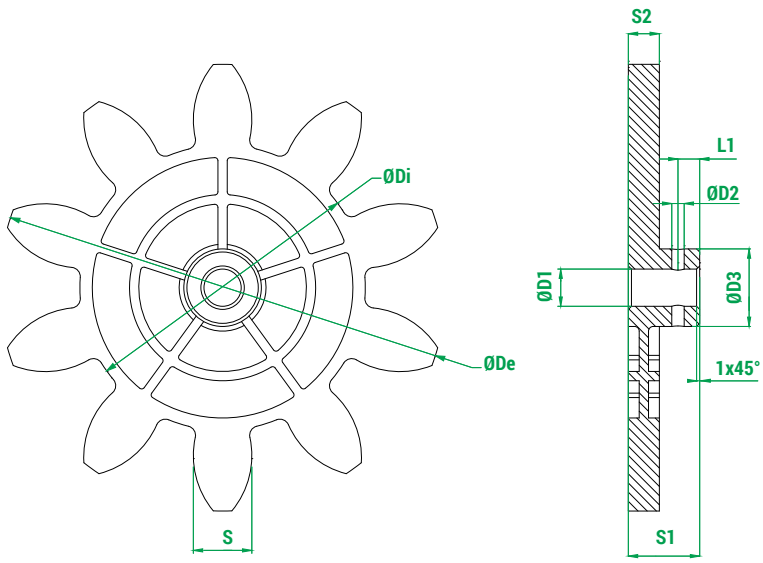

Legend	
Z	Number of teeth
M	Module
Dp	Primitive diameter
De	External diameter
Di	Internal diameter
a	Addendum
d	Dedendum
Alpha	Pressure angle

Code	Z	M	Dp	De	Di	a	d	S	Alpha	D1	D2	D3	S1	S2	L1
PRSL0915PI	8	20.00	160.00	200.00	113.20	20.00	23.40	31.41	20.00	12.00	4.00	24.00	23.00	10.00	7.00
PRSL0912PI	10	12.00	120.00	144.00	92.00	12.00	14.00	18.85	20.00	12.00	4.00	25.00	23.00	10.00	7.00
PRSL0913PI	10	14.00	140.00	168.00	107.24	14.00	16.38	21.99	20.00	12.00	4.00	24.60	23.00	10.00	7.00
PRSL0914PI	10	16.00	160.00	192.00	122.67	16.00	18.67	25.13	20.00	12.00	4.00	24.00	23.00	10.00	7.00
PRSL0917PI	11	6.00	66.00	78.00	51.96	6.00	7.02	9.42	20.00	12.00	4.00	19.00	23.00	8.00	7.00
PRSL0916PI	12	5.00	60.00	70.00	48.30	5.00	5.83	7.85	20.00	12.00	4.00	20.00	23.00	8.00	7.00
PRSL0918PI	12	8.00	96.00	112.00	77.28	8.00	9.36	12.56	20.00	12.00	3.90	21.50	23.50	10.00	7.00
PRSL0911PI	12	10.00	120.00	140.00	96.67	10.00	11.67	15.71	20.00	12.00	4.00	25.00	23.50	10.00	7.00
PRSL0944PI	12	12.00	144.00	168.00	116.00	12.00	14.00	18.85	20.00	12.00	4.00	24.00	23.00	10.00	7.00

Measuring unit: mm.

## Waterjet cut pinion gears

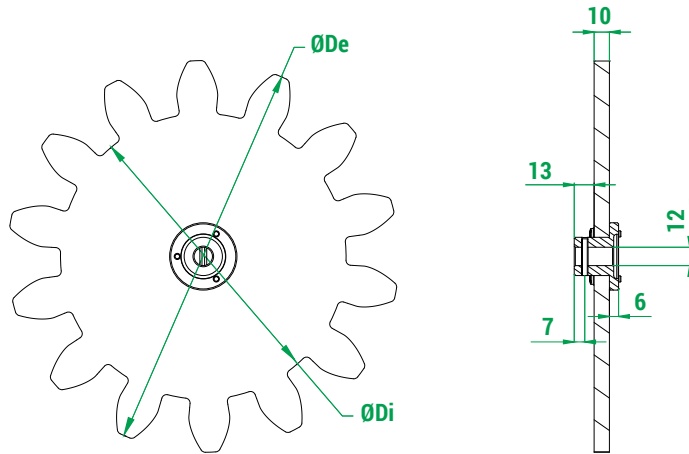

## Legend

Z	Number of teeth
M	Module
Dp	Primitive diameter
De	External diameter
Di	Internal diameter
a	Addendum
d	Dedendum
Alpha	Pressure angle

Code	Z	M	Dp	De	Di	a	d	Alpha
PRSL0857PI	8	18.00	144.00	180.00	102.00	18.00	21.00	20.00
PRSL0855PI	8	24.00	192.00	240.00	136.00	24.00	28.00	20.00
PRSL0992PI	9	10.00	90.00	110.00	66.67	10.00	11.67	20.00
PRSL0879PI	9	16.00	144.00	176.00	106.67	16.00	18.67	20.00
PRSL0854PI	9	18.00	162.00	198.00	120.00	18.00	21.00	20.00
PRSL0871PI	9	20.00	180.00	220.00	133.33	20.00	23.33	20.00
PRSL0849PI	9	24.00	216.00	264.00	160.00	24.00	28.00	20.00
PRSL0846PI	10	10.00	100.00	120.00	76.67	10.00	11.67	20.00
PRSL0993PI	10	18.00	180.00	216.00	138.00	18.00	21.00	20.00
PRSL0970PI	10	22.00	220.00	264.00	168.52	22.00	25.74	20.00
PRSL0856PI	10	24.00	240.00	288.00	184.00	24.00	28.00	20.00
PRSL0861PI	11	12.00	132.00	156.00	104.00	12.00	14.00	20.00
PRSL0998PI	11	18.00	198.00	234.00	156.00	18.00	21.00	20.00
PRSL0997PI	11	20.00	220.00	260.00	173.36	20.00	23.32	20.00
PRSL0859PI	11	24.00	264.00	312.00	204.00	24.00	30.00	20.00
PRSL0863PI	12	14.00	168.00	196.00	133.00	14.00	17.50	20.00
PRSL0897PI	12	16.00	192.00	224.00	154.67	16.00	18.67	20.00
PRSL0972PI	12	18.00	216.00	252.00	173.88	18.00	21.06	20.00
PRSL0845PI	12	20.00	240.00	280.00	193.34	20.00	23.32	20.00
PRSL0878PI	12	24.00	288.00	336.00	232.00	24.00	28.00	20.00
PRSL0860PI	13	6.00	78.00	90.00	63.00	6.00	7.50	20.00
PRSL0853PI	13	12.00	156.00	178.59	126.00	11.29	15.00	20.00
PRSL0898PI	13	16.00	208.00	240.00	170.67	16.00	18.66	20.00
PRSL6519PI	14	6.00	84.00	96.00	69.00	6.00	7.50	20.00
PRSL0862PI	14	10.00	140.00	169.00	125.00	15.00	7.50	20.00
PRSL0896PI	14	16.00	224.00	256.00	186.67	16.00	18.67	20.00
PRSL0999PI	14	18.00	252.00	288.00	210.00	18.00	21.00	20.00
PRSL0848PI	14	20.00	280.00	320.00	233.33	20.00	23.33	20.00
PRSL0858PI	15	18.00	270.00	306.00	228.00	18.00	21.00	20.00
PRSL0847PI	16	20.00	320.00	360.00	273.33	20.00	23.33	20.00
PRSL0973PI	17	10.00	170.00	190.00	145.00	10.00	12.50	22.89
PRSL0974PI	17	14.00	238.00	266.00	203.00	14.00	17.50	22.89
PRSL0851PI	20	6.00	120.00	132.00	105.00	6.00	7.50	22.89
PRSL0844PI	25	1.00	25.00	27.00	22.50	1.00	1.25	22.89

Measuring unit: mm.

# FOX - REQUEST FORM FOR NON STANDARD LIMIT SWITCH

## Instructions

(See next page for list of components and legends)

- 1 Version:** tick the required version.
- 2 SIL 1 certified:** tick the box if you require SIL 1 certified units.
- 3 Revolution ratio:** write the required revolution ratio.
- 4 Standard cam set:** write the code of the cam set required.
- 5 Customized cam set:** for non standard cam sets, fill in the scheme choosing the cams and the switches required. With switches PRSL0110XX and PRSL0111XX it is possible to assemble sets with 2, 3, 4 or 5 cams/switches. With switches PRSL0100XX it is possible to assemble onle sets with 2 or 4 cams/switches.  
  
Customized cams are available on request.
- 6 Potentiometer. encoder. Yankee:** write the code of the potentiometer, encoder or Yankee required.  
  
ATTENTION: it is possible to mount a potentiometer or an encoder alone or together with a set of 2 or 3 cams/switches. Potentiometers PA020001 and PA020002 can be mounted only with sets of 2 cams/switches.  
  
ATTENTION: Yankee may be mouted alone or together with a set of max. 4 cams/switches.
- 7 Cable clamp:** tick the cable clamp required.
- 8 Coupling. flange. pinion gear:** tick the box when coupling, flange or pinion gear are required.  
  
When a standard pinion gear is required, write the code number listed in the pinion gear charts in the catalogue.  
  
When a special pinion gear is required, write the number of teeth, the module and the primitive diameter.
- 9 Shaft:** tick the shaft type required.
- 10 Cover holding wire:** tick when the cover holding wire is required.

### Version **1**

- Version **CE EAC**
- Version **cULus CE EAC**
- Version with anti-moisture plug **CE EAC**

ATTENTION: Limit switches with switches PRSL0100XX are not cULus certified.

### SIL1 certified **2**

### Revolution ratio **3**

- 1:15                       1:150
- 1:20                       1:200
- 1:25                       1:250
- 1:50                       1:300
- 1:75                       1:450
- 1:100                     1:

### Standard cam set **4**

Cam set code \_\_\_\_\_

### Customized cam set **5**

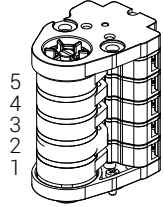

Cam code	Switch code
5 _____	_____
4 _____	_____
3 _____	_____
2 _____	_____
1 _____	_____

### Potentiometer. encoder. Yankee **6**

Code \_\_\_\_\_

### Cable clamp **7**

- M20                       M20+M16
- M20+M20

- Male coupling                       Coupling **8**
- Female coupling                       Flange
- Pinion gear

Pinion gear code \_\_\_\_\_

Customized pinion gear  
 No. of teeth \_\_\_\_\_  
 Module \_\_\_\_\_  
 Primitive diameter \_\_\_\_\_

### Shaft **9**

- Shaft made of stainless steel AISI 430F
- Shaft made of high resistance stainless steel AISI 303

### Cover holding wire **10**

#### 4 Legend - Standard cam sets

No. and type of switches	No. and type of cams	Code
2 x PRSL0110XX	2 cams A	FCL20001
	Cams A+C	FCL20003
4 x PRSL0110XX	2 cams C	FCL20005
	Cams D+D+B+F	FCL40001
	4 cams A	FCL40003
	Cams A+A+C+C	FCL40005
	4 cams C	FCL40007
	Cams C+C+C+E	FCL40009
2 x PRSL0111XX	Cams A+A+E+E	FCL40011
	2 cams A	FCL20002
	Cams A+C	FCL20004
4 x PRSL0111XX	2 cams C	FCL20006
	Cams D+D+B+F	FCL40002
	4 cams A	FCL40004
	Cams A+A+C+C	FCL40006
	4 cams C	FCL40008
	Cams C+C+C+E	FCL40010
	Cams A+A+E+E	FCL40012
	2 x PRSL0100XX	2 cams A
Cams A+C	FCN20002	
4 x PRSL0100XX	2 cams C	FCN20003
	Cams D+D+B+G	FCN40001
	4 cams A	FCN40002
	Cams A+A+C+C	FCN40003
	4 cams C	FCN40004
	Cams C+C+C+E	FCN40005
	Cams A+A+E+E	FCN40006

#### 6 Legend - Potentiometers, encoders standard and Yankee

Description	Code
Potentiometer MCB 10 kΩ with support	PA020001
Potentiometer MCB 10 kΩ mechanical stop with support	PA020002
Potentiometer Sfernice 10 kΩ ±10% 4 pins with support	PA020003
Potentiometer Sfernice 10 kΩ ±10% 3 pins with support	PA020004
Potentiometer Sfernice 5 kΩ ±10% with support	PA020005
Encoder 36 pulses./rev. with support	PA030001
Encoder 150 pulses./rev. with support	PA030002
Yankee - current output	PA01AA01
Yankee - voltage output	PA01AB01
Yankee - PWM output	PA01AC01

#### 5 Legend - Switches

PRSL0110XX	PRSL0111XX	PRSL0100XX
1NO+1NC	1NC	1NO+1NC

#### 5 Legend - Standard cams

Cam		Code for PRSL0110XX switches	Switching angle with PRSL0110XX	Code for PRSL0111XX switches	Switching angle with PRSL0111XX	Code for PRSL0100XX switches	Switching angle with PRSL0100XX
A		PRSL7194PI	21.5° ±0.5°	PRSL7194PI	23.0° ±0.5°	PRSL7124PI	16.0° ±0.5°
B		PRSL7193PI	21.5° ±0.5°	PRSL7193PI	23.0° ±0.5°	PRSL7123PI	16.0° ±0.5°
C		PRSL7195PI	82.0° ±0.5°	PRSL7195PI	86.0° ±0.5°	PRSL7125PI	75.5° ±0.5°
D		PRSL7196PI	94.0° ±0.5°	PRSL7196PI	97.5° ±0.5°	PRSL7126PI	88.5° ±0.5°
E		PRSL7191PI	204.5° ±0.5°	PRSL7191PI	203.0° ±0.5°	PRSL7121PI	196.0° ±0.5°
F		PRSL7192PI	328.5° ±0.5°	PRSL7192PI	327.0° ±0.5°	-	-
G		-	-	-	-	PRSL7122PI	327.0° ±0.5°

## USE AND MAINTENANCE INSTRUCTIONS

*Fox rotary limit switch is an electromechanical device for low voltage control circuits (EN 60947-1, EN 60947-5-1) to be used as electrical equipment on machines (EN 60204-1) in compliance with the fundamental requirements of the Low Voltage Directive 2014/35/UE and of the Machine Directive 2006/42/CE.*

The limit switch is designed for use in industrial environments under even severe climatic conditions (operational temperature from  $-40^{\circ}\text{C}$  to  $+80^{\circ}\text{C}$ , suitable for use in tropical environment). The equipment is not suitable for use in environments with potentially explosive atmosphere, corrosive agents or a high percentage of sodium chloride (saline fog). Oils, acids or solvents may damage the equipment; avoid using them for cleaning. Do not connect more than one phase to each switch. Do not oil or grease the control elements or the switches.

The limit switch is supplied with a bag of accessories including: 2 self-locking nuts (7), 2 metric screws (1), 1 no-drop wire (2), 1 self-tapping screw (3), 1 cable clamp (4). Furthermore, accessories may include, in addition to the above-mentioned parts and instead of the cable clamp (4), 1 double cable clamp holder (14), 2 cable clamps M20 (15) or 1 cable clamp M20 (15) and 1 cable clamp M16 (16).

The installation of the limit switch shall be carried out by expert and trained personnel. Wiring shall be properly done according to the current instructions.

Prior to the installation and the maintenance of the limit switch, the main power of the machinery shall be turned off.

### Steps for the proper installation of the limit switch

- Place the self-locking nuts (7) in their seats in the enclosure (6).
- Insert one end of the no-drop wire (2) into the self-tapping screw (3) and tighten the screw into its hole on the enclosure (6).
- Connect the limit switch shaft (8) and the reduction gear shaft avoiding any misalignment between the two shafts.
- Fix the limit switch tight in order to avoid vibrations of the equipment during operation; for fixing operations use only the feet (9) with metric screws M4 or M5 and their washers.
- In case a single multicore cable is employed, screw the cable clamp (4) to the enclosure (6); when two multicore cables are employed, use the cable clamp holder (14), then screw cable clamps (15, 16) to the cable clamp holder.
- Insert the cable into the limit switch through the cable clamp (4, 15, 16).
- Strip the multipole cable to a length suitable for stripping the single poles; we suggest the use of pin terminals.
- Clamp the wire into the cable clamp (4, 15, 16).
- Connect the switches according to the contact scheme printed on the switches or to the wiring scheme on the back of the instructions (tighten the wires into the terminals with a torque equal to 0.5 Nm; (UL (c)UL: use  $60^{\circ}\text{C}$  or  $75^{\circ}\text{C}$  copper (CU) conductors and stiff or flexible wire 14-16 AWG); insertability of wires into the terminals  $2 \times 0.5 \text{ mm}^2$   $2 \times 1.5 \text{ mm}^2$   $1 \times 2.5 \text{ mm}^2$ ).
- Adjust the operating point of the cams; for proper adjustment, loosen the central screw (12) of the cam set,

adjust the operating point of each single cam by turning its adjusting screw (11) (the numbers on the screws refer to the cams counting from bottom to top of the set), then tighten the central screw (12).

- Insert the free end of the no-drop wire (2) into one of the metric screws (1), then tighten the metric screws (1) to close the limit switch; check the proper positioning of the rubber in the cover (5) and tighten the screws (1) with a torque of 80/100 cNm.

### Steps for routine maintenance

- Check the proper tightening of the screws (1) of the cover (5).
- Check the proper tightening of the switch terminal screws.
- Check the proper tightening of the central screw (12) holding the cams (11).
- Check the wiring conditions (in particular where wires clamp into the terminals).
- If there is an anti-moisture plug, check its conditions.
- Check the conditions of the rubber fit into the cover (5) and check the tightening of the cable clamp (4, 15, 16) around the cable.
- Check that the limit switch enclosure (5, 6) is not broken.
- Check the alignment between the limit switch shaft (8) and the reduction gear shaft.
- Check that the limit switch is properly fixed.

Any change to parts of the limit switch will invalidate the rating plate and identification data of the device, and render the warranty null and void. In case of replacement of any part, use original spare parts only.

TER declines all responsibility for damages caused by the improper use or installation of the equipment.

### UL Specifications with PRSL0110XX or PRSL0111XX switches

#### UL Technical Specifications

UL certified Fox Code = PFB9U67L XXXX XXX  
= PFB9U67M XXXX XXX

Switches Rating = A600, Q600

Environmental Rating = Type 1, 4 and 4X

Cord type = flexible, type minimum SW or SJW (ZJCZ/7)

Wire size range = 14-16 AWG stranded or solid

Conductors = Copper (CU) 60/75°C

Terminal tightening torque = 0.5Nm (4.50 lb.in)

Tightening torque of the cover screw = 1Nm (8.85 lb-inc)

Marking = 